



We'll get you there.

CPAs | CONSULTANTS | WEALTH ADVISORS

Fifth Annual Higher Education Virtual Conference

February 21, 2023



The information herein has been provided by CliftonLarsonAllen LLP for general information purposes only. The presentation and related materials, if any, do not implicate any client, advisory, fiduciary, or professional relationship between you and CliftonLarsonAllen LLP and neither CliftonLarsonAllen LLP nor any other person or entity is, in connection with the presentation and/or materials, engaged in rendering auditing, accounting, tax, legal, medical, investment, advisory, consulting, or any other professional service or advice. Neither the presentation nor the materials, if any, should be considered a substitute for your independent investigation and your sound technical business judgment. You or your entity, if applicable, should consult with a professional advisor familiar with your particular factual situation for advice or service concerning any specific matters.

CliftonLarsonAllen LLP is not licensed to practice law, nor does it practice law. The presentation and materials, if any, are for general guidance purposes and not a substitute for compliance obligations. The presentation and/or materials may not be applicable to, or suitable for, your specific circumstances or needs, and may require consultation with counsel, consultants, or advisors if any action is to be contemplated. You should contact your CliftonLarsonAllen LLP or other professional prior to taking any action based upon the information in the presentation or materials provided. CliftonLarsonAllen LLP assumes no obligation to inform you of any changes in laws or other factors that could affect the information contained herein.

Learning Objectives

At the end of this session, you will be able to:

- Recognize the evolution of higher education over the past 60 years
- Recognize the meaning of culture, how it evolves, and the important role of both STEM and the Humanities/Social Sciences throughout American higher education and society
- Recall innovative ways institutions have used data
- Identify ways your institution can move forward with digital transformation
- Identify and adopt promising practices affecting affordability, value, and access
- Identify how to integrate value and affordability with the strategic plan
- Recall the collaboration between finance and academic affairs to advance student success, affordability, and value





Freeman A. Hraboski, III

President Emeritus of UMBC



We'll get you there.

CPAs | CONSULTANTS | WEALTH ADVISORS

What Does Digital Transformation Look Like in Higher Education?

Agenda:



Who We Are

Let's Get to Know Each Other



Learning Objectives

Set the Stage for Today's Session



Summit Academy

Review the Mission, Vision & Challenges

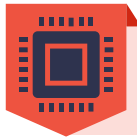

The Digital Journey

How Digital Is Transforming Summit



Key Takeaways

What Does This Mean for You?



Q&A

Let's Answer Your Questions



Who We Are



Deirdre Hodgson

Managing Principal, Higher
Education

CLA



Megan Normandin

Director, Monitoring &
Evaluation

Summit Academy



Tyler Coher

Manager, Digital

CLA



Learning Objectives

1

Highlight & Understand Common Challenges Higher Education Institutions Face Today With Increasing Data Demands, Legacy Systems & Manual Processes

2

Review & Dissect Innovative Ways Institutions Have Leveraged Digital to Improve Their Operations, Outcomes & Student Experiences

3

Help You Understand Tangible Steps You Can Take to Enhance Your Organization Through Leveraging the Power of Digital



The Summit Academy Mission



We exist to assist individuals in developing their ability to earn and to become contributing citizens in their community.

the best social service program in the world is a job





Who we are

- Career & Technical Education
- In-demand entry-level careers
- + GED and youth STEM
- North Minneapolis, MN
- No out-of-pocket costs
- SAOIC.org



The Summit Academy Model

Path to the Middle Class

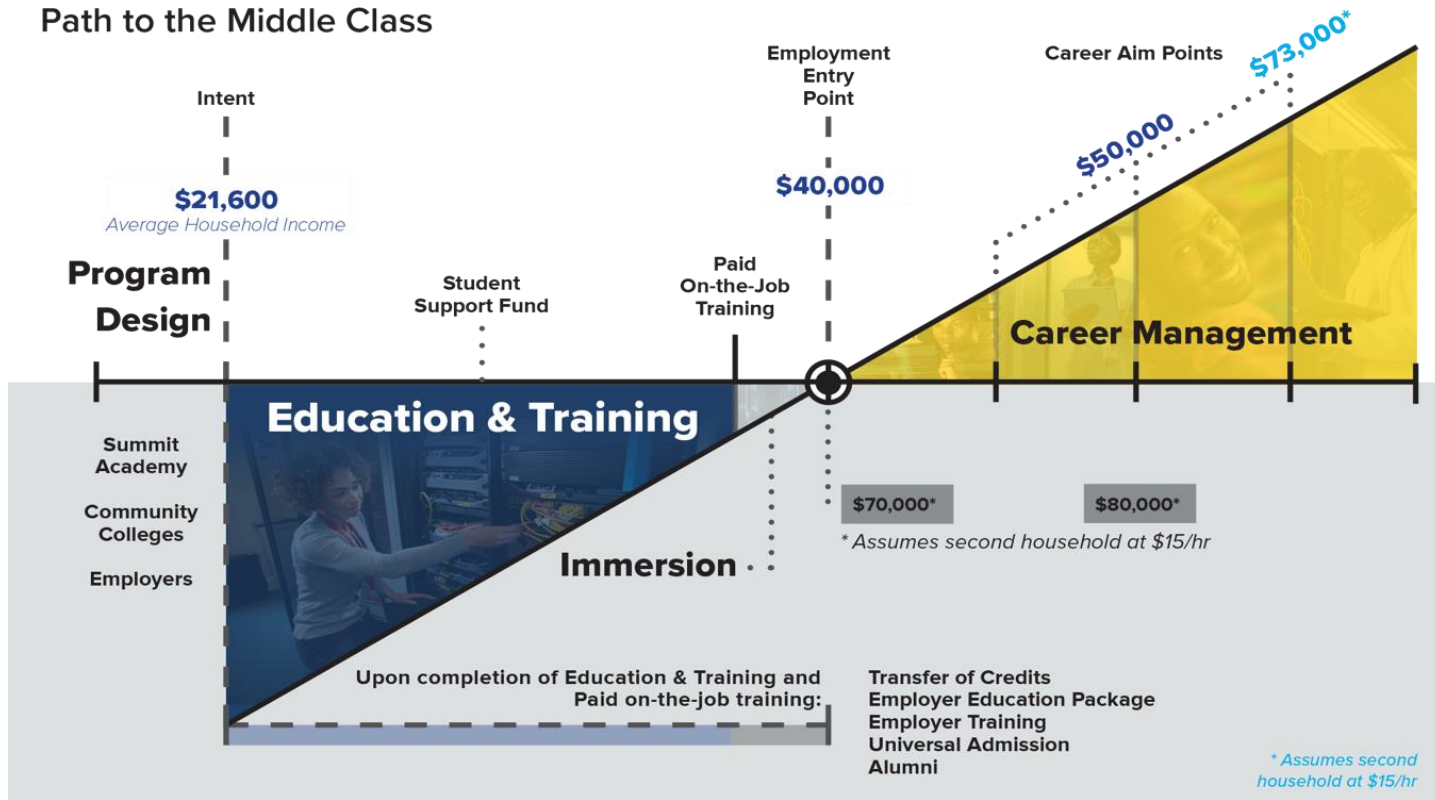

Summit Academy's Impact

2022 IMPACT

Data reflects activities July 1, 2021 - June 30, 2022



902

Students enrolled



677

Students identified as a person of color



422

Students were unemployed at enrollment



582

Students were earning less than \$27,180 at enrollment

420 students placed in a career



97% placed in their field of study



96% placed in full-time employment



411 students have been awarded a GED since 2016



1,607 youth participated in a STEM program



\$40,160 average earnings

Growth

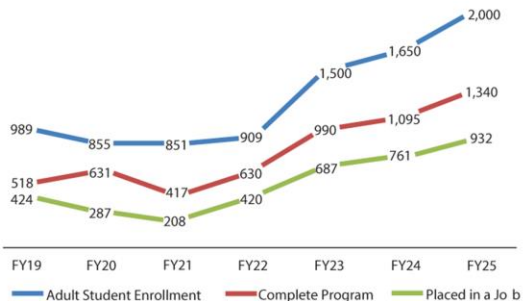

Identifying the Need / Issue



- 80 - 90 employees
- ~\$10 mil annual operating budget
- Limited Expertise in Digital Transformation



Summit's Digital Journey

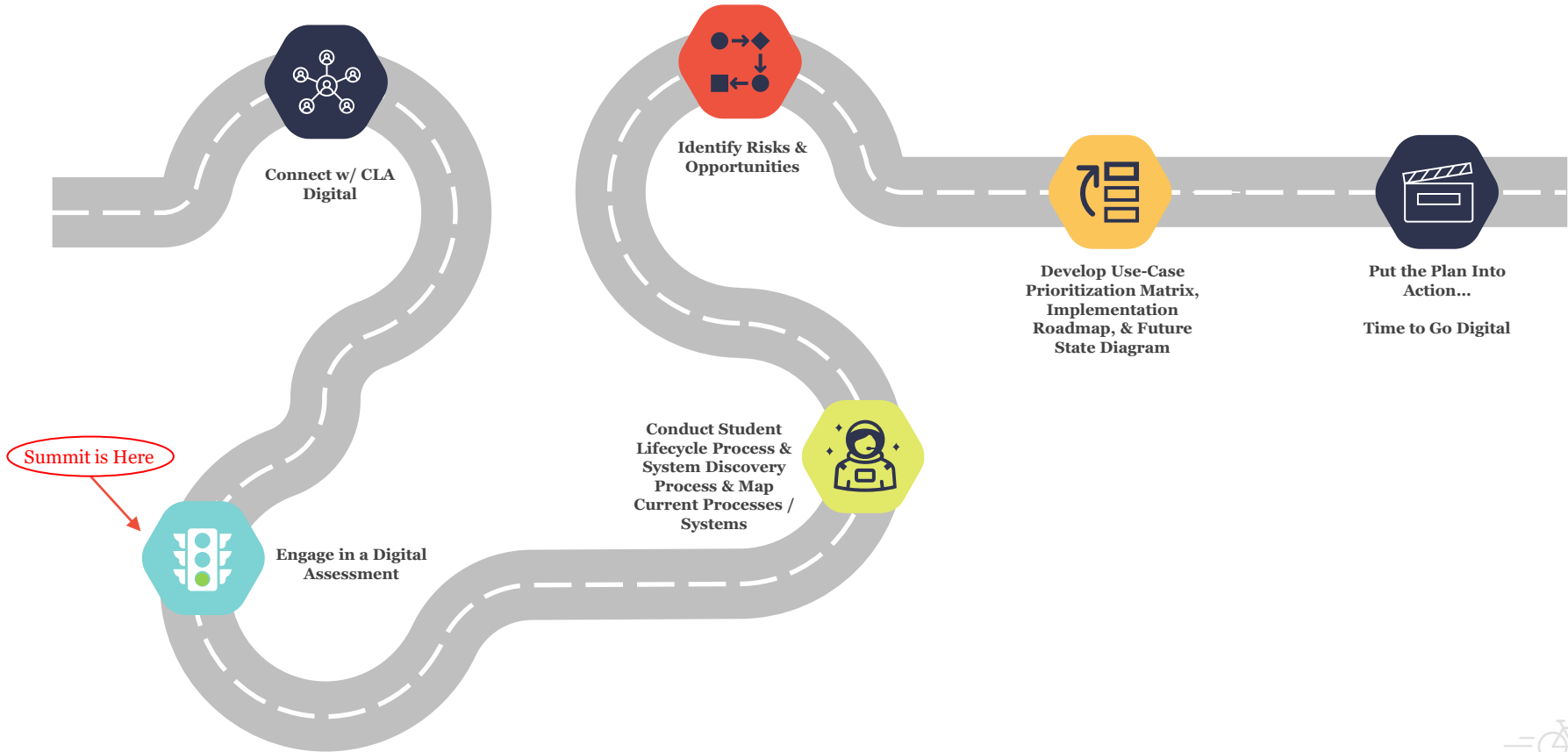

What is a Digital Assessment?

Phase 1: Discovery Sessions & Data Source Evaluation	Review existing reports, dashboards, data sources, and infrastructure and conduct discovery sessions with key stakeholders selected collaboratively.
Phase 2: Development of Implementation Roadmap	Utilize findings from discovery sessions and data source evaluation to create an Implementation Roadmap with associated recommendations.
Phase 3: Final Delivery	<p>Final findings and deliverables to be presented, including:</p> <ul style="list-style-type: none">• <i>Implementation Roadmap</i>: This will include a timeline to select/develop use cases, and illustrate the various options, and associated costs, of executing the data strategy.• <i>Use-Case Prioritization Matrix</i>: Prioritized and created in collaboration with Crew's key stakeholders. This matrix will serve as a tool to identify the effort for future data strategy efforts while measuring the organizational value and feasibility of each use-case.• <i>Data Source Catalog</i>: CLA will identify and catalog all existing reports, dashboards, data sources, and applications.• <i>Discovery Session Review</i>: CLA will conduct a session to illustrate and review all key findings from the discovery session interviews



Summit's Digital Journey

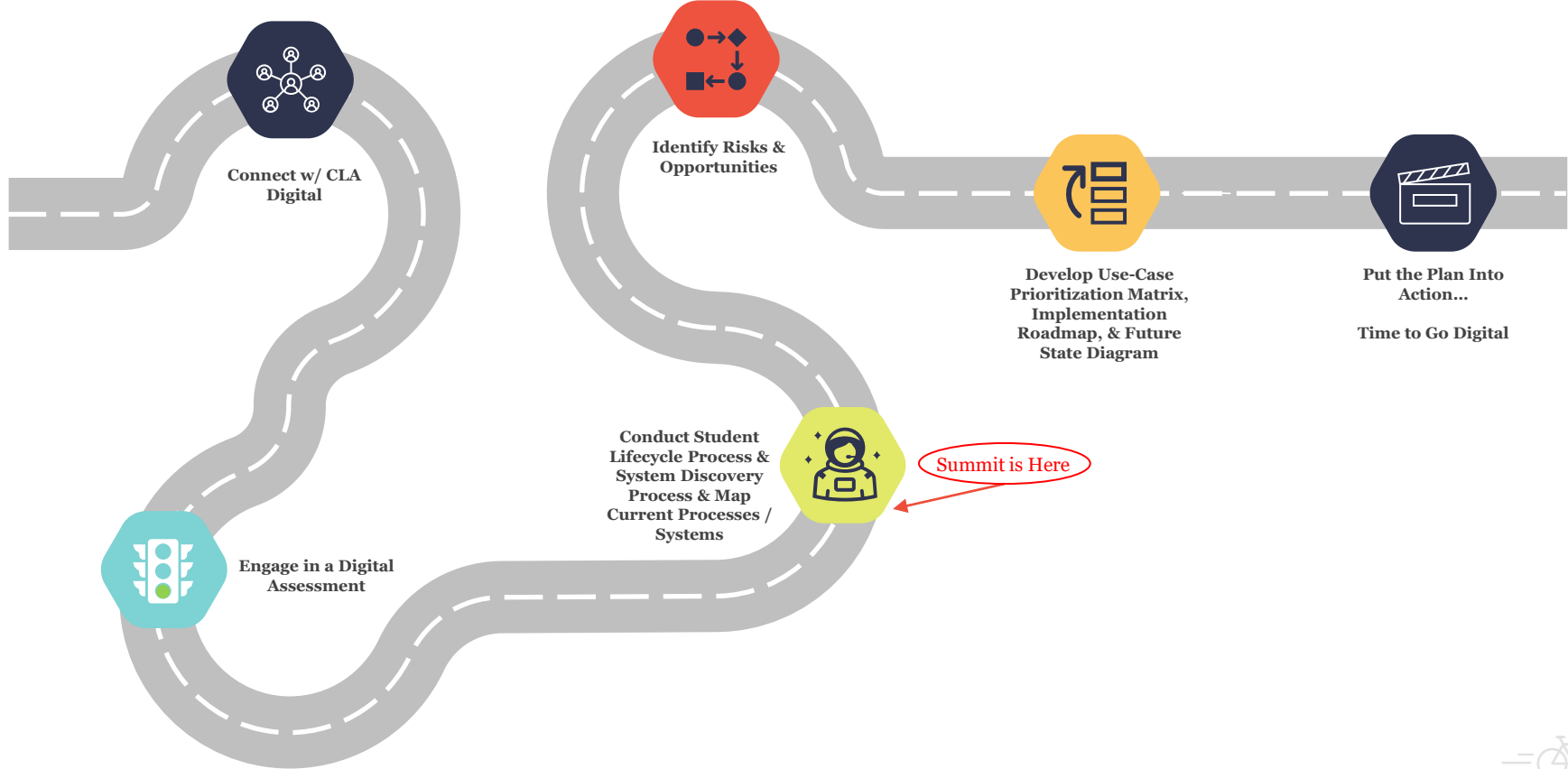

Current State Process Overview

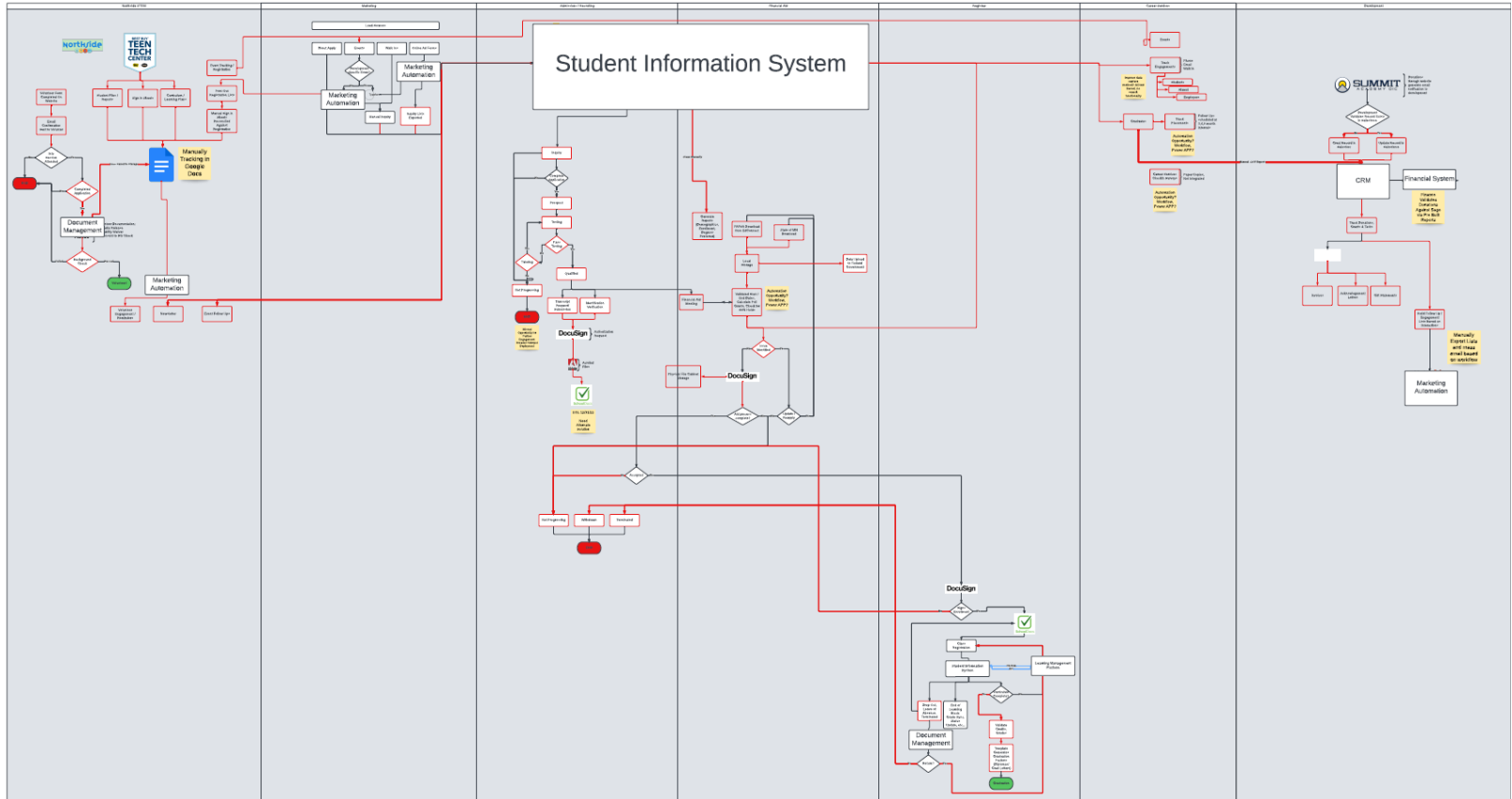

Summit's Digital Journey

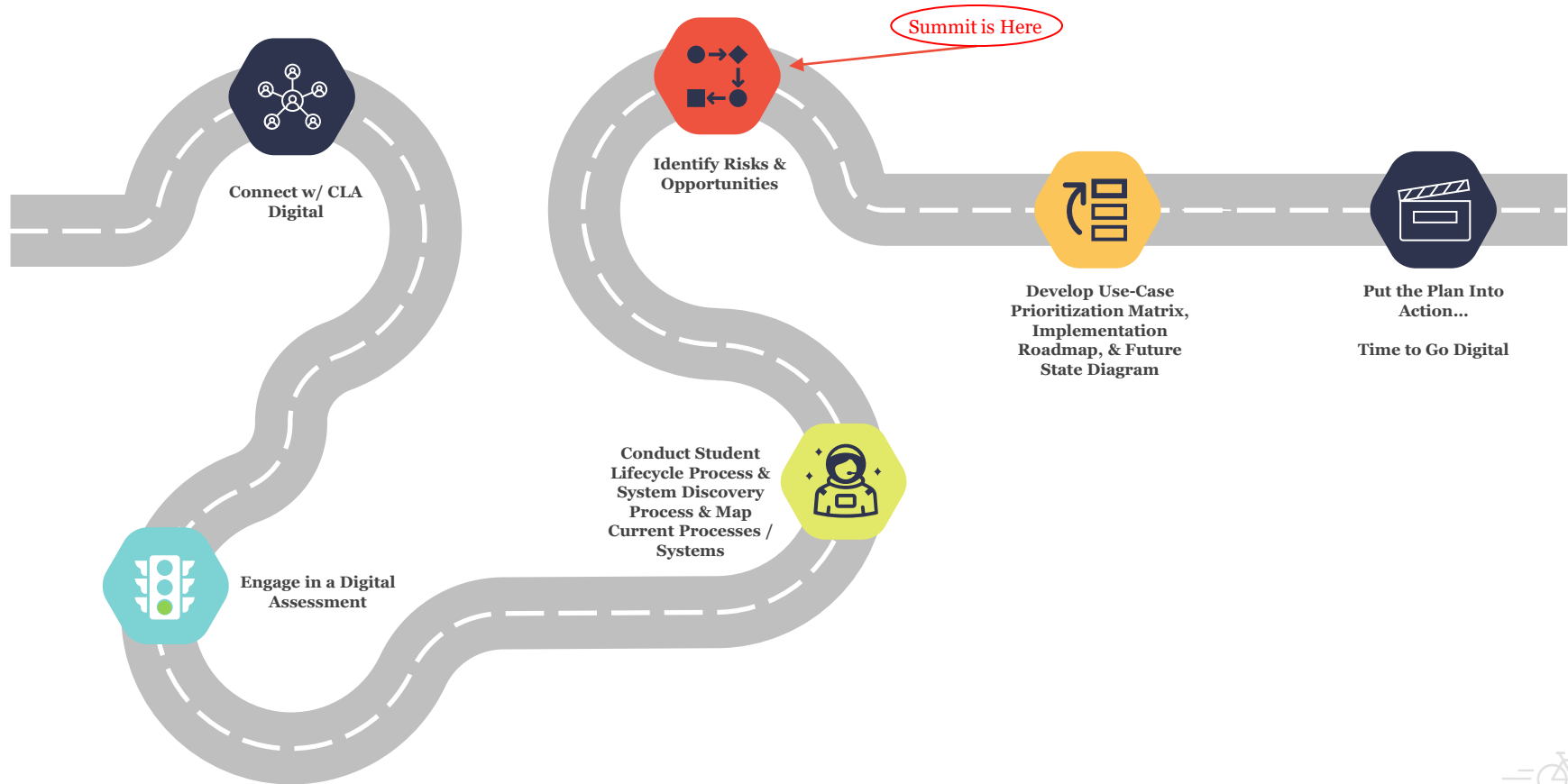

Key Assessment Findings



Student Lifecycle Management System Lacking In Features / Functionality

Many Disconnected, Disparate Systems

Expiring Document Management Solution



Existing Processes Heavily Reliant on Manual Effort / Input

Processes Not Optimally Defined

Very Prone to Error

Resources Constrained & Stretched Thin



No Streamlined Data Access

KPIs Difficult to Track Resulting in Less Than Optimal Outcomes

Makes Evaluating What Works & What Doesn't Difficult



Lack of Institutional Knowledge About How to Approach Solving Such Complex, Interconnected Issues

Just Trying to Run the Organization Is Hard Enough



Summit's Digital Journey

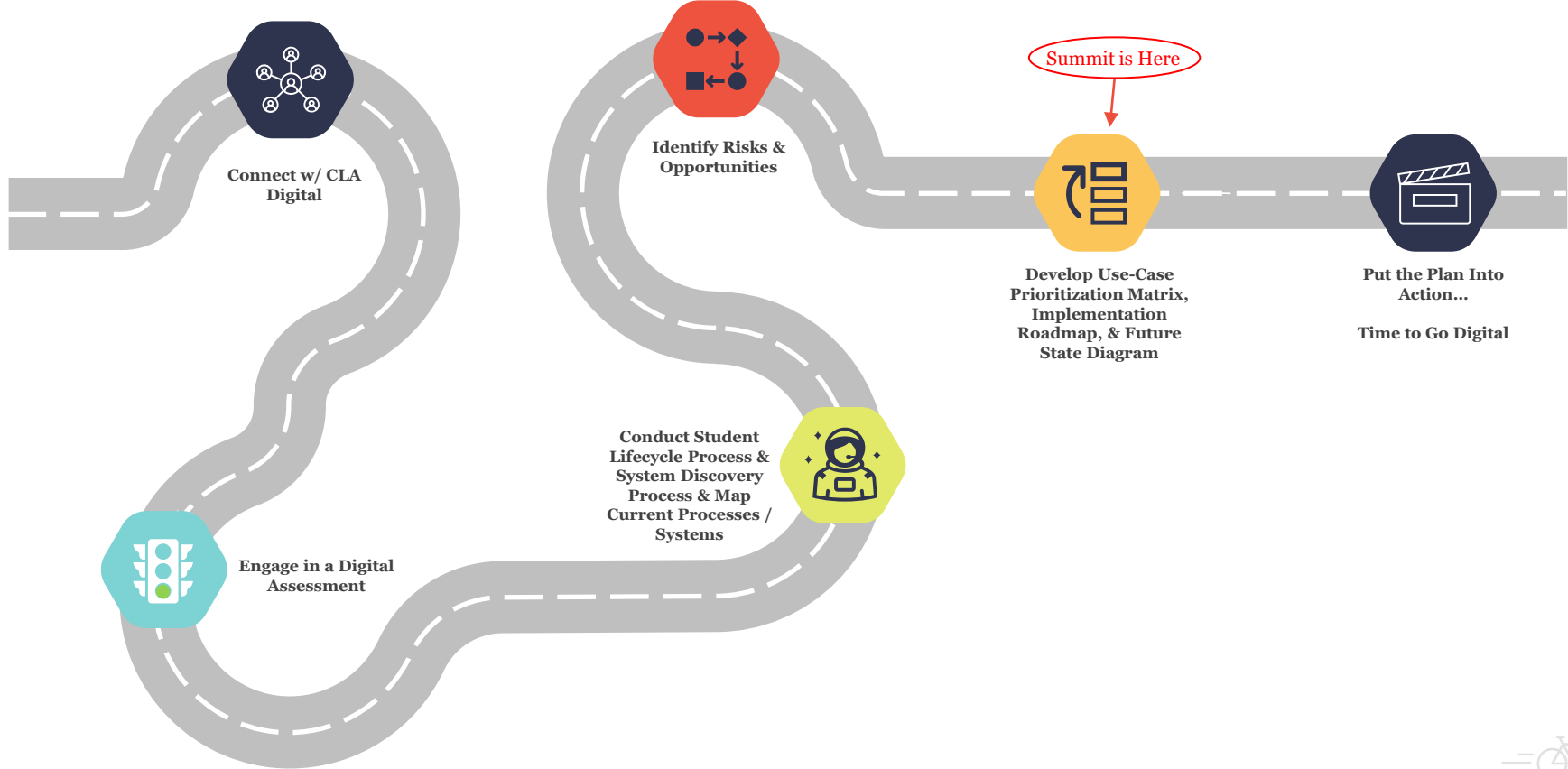

Summit Use-Case Prioritization Matrix



Use-Case Prioritization Matrix

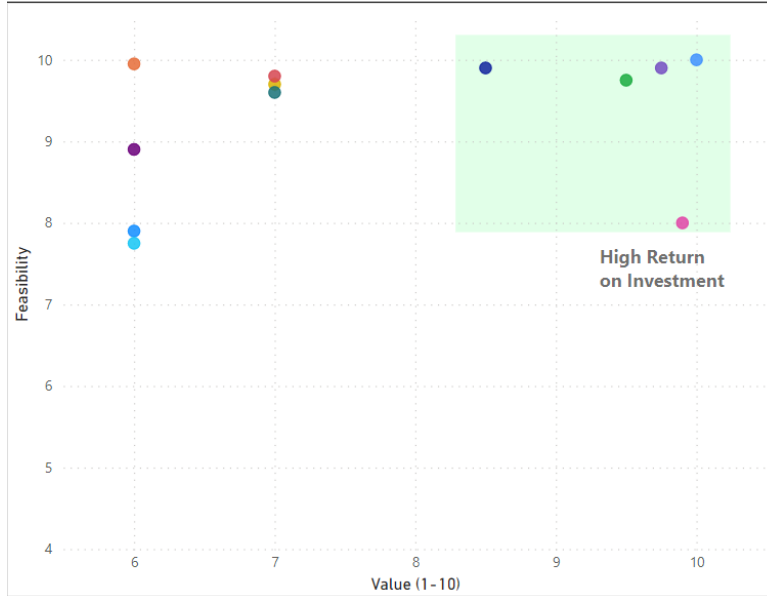

Total # of Use-Cases = 12

Value	Feasibility	Use-Case		
6.00	10.00	All		
7.75	10.00	All		
Use-Case Name/Description			Value	Feasibility
Software Evaluation & Selection				
Conduct Deep-Dive Evaluation of Salesforce & Microsoft Dynamics to Explore SOP Mapping /Consolidating Disparate Systems & Workflows			10.00	10.00
Implement Selected Solution				
Implement & Customize Selected Solution to Support / Facilitate Summit Academy's Standard Operating Procedures			9.90	8.00
Integrate New Solution w/ Canvas & Anthology Via API Connections				
Connect Existing Systems (Canvas & Anthology) to Software Solution Leveraging Available API Integrations			9.75	9.90
Migrate Historical Documents Into New Solution				
Once New Solution is in Place, Migrate Historical Documents to New Location			9.50	9.75
Consolidated BI / Reporting Development				
Develop Custom Dashboards/Reports/Insights to Serve the Needs of the Organization and Enhance Speed to Information Baseline			8.50	9.90
KPI Consolidation				
Select / Refine the Most Significant KPI's for Summit Academy. Once These Core KPI's are Agreed Upon, Departmental/Individual KPI's Should be Solidified.			7.00	9.70
KPI Identification				
Conduct an Exercise / Discovery Session(s) to Brainstorm, Identify and Prioritize KPIs Critical to the Success of the Organization			7.00	9.80
KPI Segmentation				
Once the KPIs Have Been Identified and Refined, They Should be Segmented by Organizational Function and Prioritized Into Red, Yellow, and Green Bands so They are Actionable an Individual, Departmental, and Organizational Perspective.			7.00	9.60
Ad-Hoc Reporting				
For data Not Available in the Defined Dashboards and Reports, an Ad-Hoc Reporting Structure Should be Developed and Implemented			6.00	7.90
Data Calendar				
A Data Calendar Will Illustrate the Seasonality of Data and Ad-Hoc Reporting Needs at Summit Academy Allowing Employees to Proactively Utilize Information Rather Than Reacting to Student/Market Trends.			6.00	9.95
Data Governance Standards Implementation				
To Track the Availability, Utility, and Security of Summit Academy's Data, a Data Governance Program Should be Implemented			6.00	8.90
Self-Service Analytics				
In Addition to Creating the Standardized Dashboards by Department, Individuals Desire the Capability to Analyze Data to Their Specifications, With the Ability to Generate Custom Reports and Dashboards from Pre-Curated Data			6.00	7.75



Proposed Future State



Summit's Digital Journey

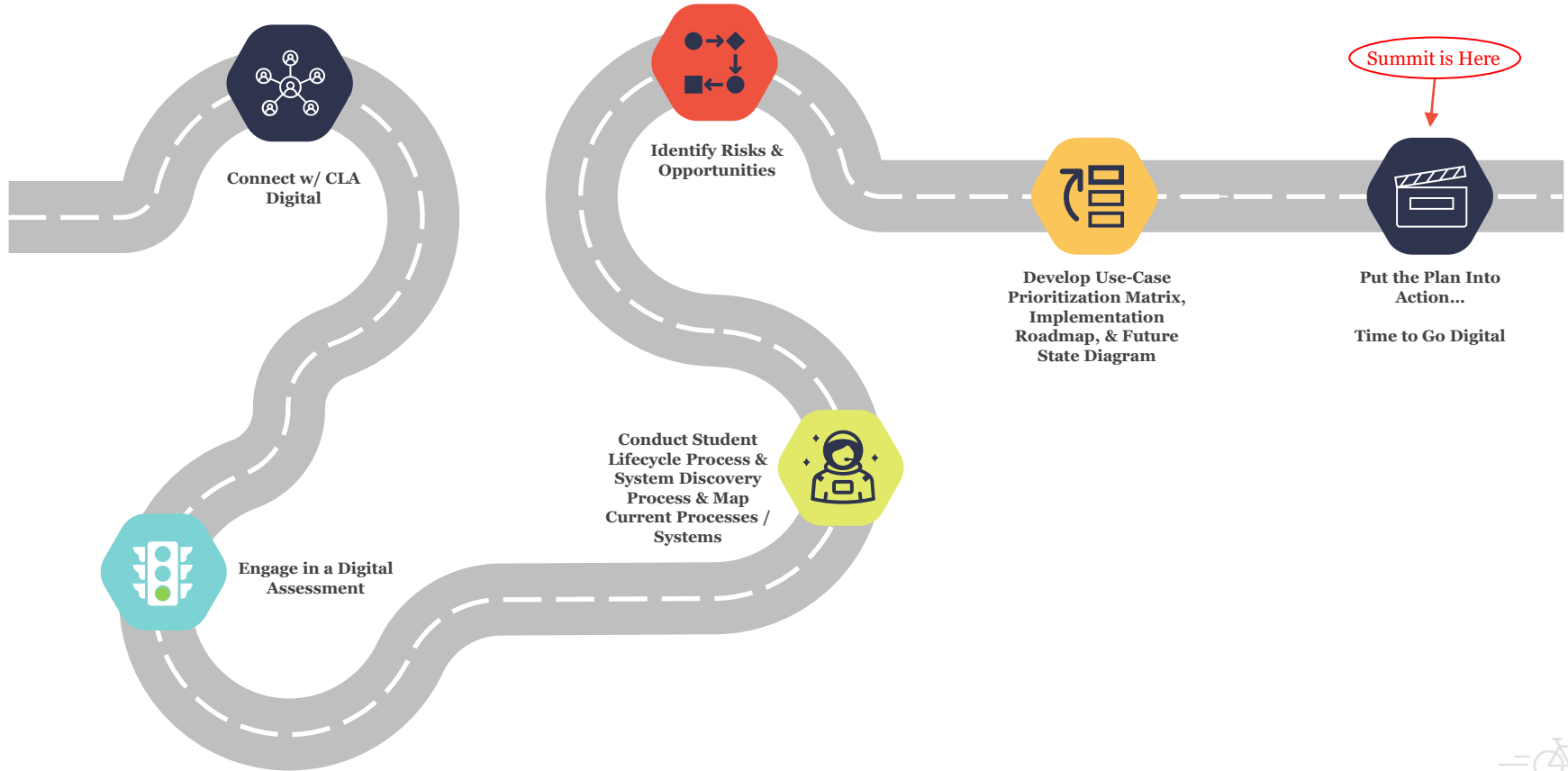

Initial Solution: ERP Integration

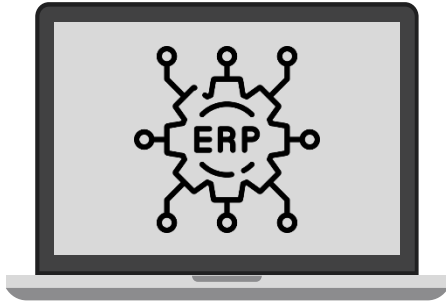

Full Student Lifecycle
Process Management
w/ Integrated Website
Forms & Process
Automations

Benefits

- **Facilitates The Connection Of Disparate Data Sources / Business Applications**
 - Consolidates Multiple Databases Into Common, Easily-Accessible Location For Management / Interaction By Multiple Users
- **Enhances Security / Redundancy Through Cloud-based Backups & Eliminates Many Existing Business Continuity Risks**
- **Allows For Development & Deployment Of Business Process Automations To Drive Cross-functional Operational Efficiencies**
 - Automatic Updates, Record Deduplication, Streamlined Record Updates
- **Web-Based Access**
 - Users Can Access / Interact W/ From Any Internet Connected Device...No VPN Or Onsite Credentialing Required
- **Highly Customizable To Your Specifications**
- **Plenty Of Off-The-Shelf Solutions**



Key Takeaways for Higher Education Institutions





Thank You!



We'll get you there.

CPAs | CONSULTANTS | WEALTH ADVISORS